

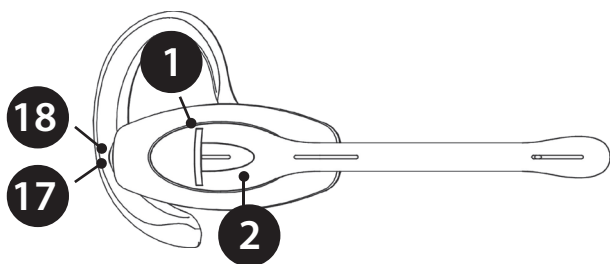

IPN W880

Operation Manual

- 1 Headset 'ON/OFF' LED
- 2 Headset 'ON/OFF' button
- 3 Power LED
- 4 Headset charge LED
- 5 Headset 'IN USE' LED
- 6 Battery LED indicator
- 7 Telephone switch with ON/OFF LED ('TEL' LED)
- 8 PC/USB switch with ON/OFF LED ('PC/USB' LED)
- 9 Microphone volume up
- 10 Microphone volume down
- 11 USB port
- 12 AUX port
- 13 Power socket
- 14 Handset connector
- 15 Telephone connector ('TEL' port)
- 16 Wiring switch
- 17 Receive volume up/down
- 18 Mute button
- 19 Battery charging slot
- 20 Battery remove button

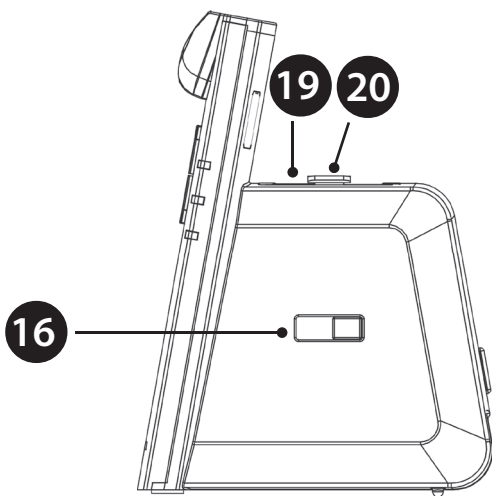
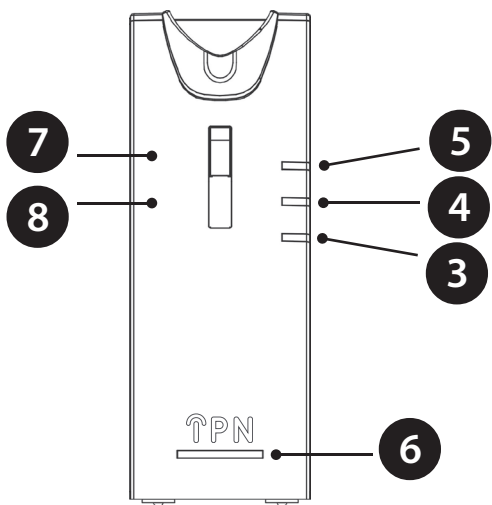

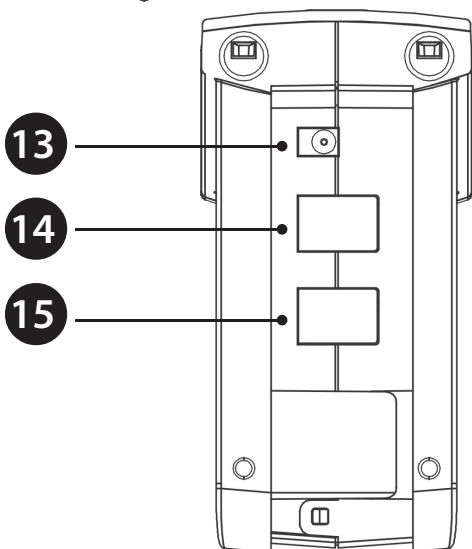
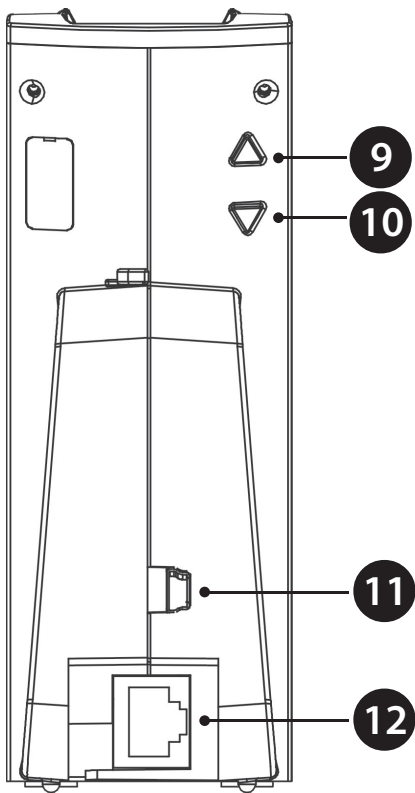

Contents:

1. Product description

2. Setup

- 2.1 Connecting to a telephone or terminal with a headset port
- 2.2 Connection to a telephone or terminal without a headset port
- 2.3 Connecting to a compatible handset lifter (refer to your supplier)
- 2.4 Connecting to a computer USB port
- 2.5 Wearing style

3. Operation

- 3.1 Making and receiving calls
 - 3.1.1 Making an outgoing call in telephone mode
 - 3.1.2 Receiving an incoming call in telephone mode
 - 3.1.3 Making an outgoing call in VOIP mode
- 3.2 Adjusting the ring volume
- 3.3 Muting the headset microphone
- 3.4 Headset transmitting volume setting
- 3.5 Adjusting headset receive volume
- 3.6 Out of range and reconnection
- 3.7 Battery hotswap
- 3.8 Battery level indication
- 3.9 Making a conference call
- 3.10 Overview of audio signals
- 3.11 Registering a new headset to the base
- 3.12 Using the W880 for call recording

4. Troubleshooting

1. Product description

The IPN DECT is a fully wireless headset solution offering the user the ability to work 'handsfree' with true wireless mobility.

Main features:

- DECT wireless headset solution
- Convertible into two wearing styles: headband & earhook
- Up to 6.5 hours talk time without recharging
- Auxiliary port for connecting handset lifter or electronic hookswitch device
- Noise cancelling microphone for reduced background noise
- Secure high quality audio
- Receive volume control on headset
- Mute button on headset
- Talk button with LED on headset
- Range up to 400m
- 'Out of range' warning
- DECT/GAP compatible
- Second battery storage/charging point on base
- PC/USB connectivity (*)
- Three way conferencing by connecting additional headset

** Will connect to Apple Mac or PC running Windows 98, Windows 2000, Windows XP, Windows Vista and Windows 7.*

2. Setup

- Connect the power adaptor supplied with the product to the base unit (13). The base power LED (3) will light. If the base is in telephone mode, the 'TEL' LED (7) will light, otherwise, the 'PC/USB' LED (8) will light.

- Install the battery into the headset if not fitted. The little line on the battery has to match the line on the battery slot, otherwise the battery will not fit.
- The headset LED (1) will turn on for about 2 seconds then turn off. Now your headset is in standby mode.

NOTE: The first time you use your headset, it is recommended that the headset is charged for a minimum of 4 hours before use.

2.1 Connecting to a telephone or terminal with a headset port

- Using the headset cord supplied with the product, connect the 'TEL' port (15) on headset base with the headset port on your telephone.
- Use the power adaptor supplied with the product to connect the headset base (13) to a power socket.
- You may need to adjust the wiring switch (16) that is located on the side of the headset base to find the correct wiring for your device.

2.2 Connecting to a telephone or terminal without a headset port

- Using the headset cord supplied with the product, connect the 'TEL' port (15) on headset base with the 'handset' port on your telephone.
- Connect the telephone handset cord to the handset (14) port on the headset base.
- Use the power adaptor supplied with the product to connect the headset base (13) to a power socket.
- You may need to adjust the wiring switch (16) that is located on the side of the headset base to find the correct wiring for your device.

2.3 Connecting to a compatible handset lifter (refer to your supplier)

- Fit the handset lifter to your telephone as indicated in its user guide.
- Connect the handset lifter to the 'AUX' port (12) located on the back of the headset base.

With the handset lifter connected, you will be able to answer and end calls using the button located on the headset while away from your desk.

2.4 Connecting to a computer USB port

- Connect the USB cable supplied with the product to the 'USB' port (11) on the back of the headset base and to a available USB port on your computer.
- The computer should automatically recognise the device and install the correct drivers.

2.5 Wearing style

Your IPN DECT headset is supplied with a headband and an earhook.

- **Headband**
This can be attached to the headset to allow for either left or right ear wearing and the size can be adjusted to allow the user to find the most comfortable fit.
- **Earhook**
This can also be used on either the left or right ear.

To remove the headband or earhook: put your thumb on the speaker and carefully pull the headband or earhook with your other hand towards you.

3. Operation

3.1 Making and receiving calls

3.1.1 Making an outgoing call in telephone mode

- Ensure that the 'TEL' button (7) on the front of the headset base is selected.
- Lift the headset from the base to start the call. If you are already wearing the headset press the headset's 'ON/OFF' button (2). The base 'IN USE' LED (5) will light. If a handset lifter or electronic hookswitch device is connected to the headset base, the line will be seized. Otherwise, you will also need to activate the headset port via your telephone terminal.
- Dial the telephone number on the telephone terminal
- After finishing the call, replace the headset on the base or press the ON/OFF button (2) to disconnect. The 'IN USE' LED (5) will turn off.

3.1.2 Receiving an incoming call in telephone mode

- If there is an incoming call from the telephone line and the headset base is connected to a handset lifter or electronic hook switch device, the 'TEL' LED (7) and headset LED (1) will flash, also a ring tone will be heard on the headset.
- Lift the headset from the base to answer the call. If you are already wearing the headset press the headset's 'ON/OFF' button (2). The base 'IN USE' LED (5) will light. If a handset lifter or electronic hookswitch device is connected to the headset base, the line will be seized. Otherwise, you will also need to activate the headset port via your telephone terminal.
- To end the call, replace the headset on the base or press the headset ON/OFF button (2).

3.1.3 Making an outgoing call in VOIP mode

- Ensure that the 'VOIP' button (8) on the front of the headset base is selected.
- Lift the headset from the base or press the headset's ON/OFF button (2) if you are already wearing it and the base 'IN USE' LED (5) will light.
- After finishing your VOIP call, press the ON/OFF button (2) to disconnect. The headset LED (1) and the base 'IN USE' LED (5) will turn off.

3.2 Adjusting the ringing volume

When the headset is ringing to indicate an incoming call, you can adjust the ring volume by moving the rocker switch (17) at the back of the headset.

3.3 Muting the headset microphone

To mute the headset microphone when on a call, press the mute button (18) on the back of the headset. While the headset is in mute mode, a short beep will be heard on the headset every 8 seconds. Press the mute button (18) again to release the mute.

3.4 Headset transmitting volume setting

During a call you can adjust the transmit volume of the headset by using the two buttons (9 and 10) located on the back of the headset base.

3.5 Adjusting headset receive volume

Use the rocker switch (17) at the back of the headset to adjust the receive volume on your headset. You will hear a beep sound for each volume step up or down.

3.6 Out of range and reconnection

You will hear a warning tone in the headset when you walk out of range of the base. The headset will be disconnected from the base and the call will be automatically placed on hold. If you move back inside the range of the base the headset will automatically reconnect and the call will be active again.

NOTE: If you do not move back inside the base range within 5 minutes the call will be disconnected.

3.7 Battery – hotswap

The user can “hotswap” the headset battery while on a call. When the battery is removed from the headset, the base unit will put the call on hold for a maximum of 5 minutes.

When the new battery is fitted to the headset, the ‘IN USE’ LED (1) will turn on and the call will be active again.

Put the second battery in the battery charging slot (19) on the top side of the base. The battery can be removed by sliding the battery remove button (20) sideways.

3.8 Battery level indication

The four LEDs (6) on the front of the headset base indicate the battery level of your headset battery.

Indication	Battery level
One LED flashing	< 20%
One LED on	20%-40%
Two LEDs on	40%-60%
Three LEDs on	60%-80%
Four LEDs on	80%-100%

3.9 Making a conference call

Your IPN DECT headset allows a second headset to be temporarily connected to the base so that you can have a three way conference call.

- Setup the call using the primary headset unit.
- Once on the call, place the second IPN DECT headset unit on the base charger.
- After about one second, the headset 'IN USE' LED (1) of the new headset will turn on and the base 'IN USE' LED (5) will flash to indicate the headset is registering with the base unit.
- Once the registering has completed, the base 'IN USE' LED (5) will stop flashing and the additional headset LED will flash.
- Once the registration has completed, a confirmation sound will be heard on the primary headset.
- Lift the additional headset from the base and it will enter talk mode. The two headsets are now in conference mode.

NOTE: The additional headset will only remain registered to the base for the duration of the call. After the primary headset has ended the call, the unit will return to its normal state.

The IPN DECT headset also allows you to make a conference call between your normal phone and a PC or MAC computer.

To activate this option hold down the PC/USB switch (8) for four seconds. Both LEDs of the PC/USB (8) and TEL (7) buttons will light. If one of the buttons is touched again this function will be switched off and the headset will return to the mode of the button pressed.

3.10 Overview of audio signals

Action	Audio indication
Low battery	2 rapid beeps (60 sec repeat)
Nearly out of range	2 beeps
Out of range	2 pitch tone
Back in range	4 rapid beeps
Receiver volume up/ down	1 beep
Mute on	2 pitch tone (8 sec repeat)
Mute off	1 beep
Ringer (EH device)	Multi tone (2 sec repeat)

3.11 Registering a new headset to the base

You can register a new primary headset unit to your IPN W880 base using the following procedure:

- Press and hold the 'TEL' button (7) on the headset base for five seconds to enter the registration mode. The 'TEL' LED (7) will flash to indicate it is now in registration mode.
- Press and hold the 'mute' button (18) on the back of the headset for five seconds for the headset to enter the registration mode. The headset LED (1) will flash twice and then light-up during the registration mode period.
- The headset will now be registered to the base which will take around 30 seconds. When the registration has completed, the headset LED and the base 'TEL' LED (7) will stop flashing.

3.12 Using the W880 for call recording

With the W880 it is possible to connect a normal telephone call to the USB port of your computer. This feature can be used to record phone calls with voice recording software on your PC.

On the CD-Rom that came with your headset you will find Vidicode demo call recording software which can be used for this purpose.

To activate the recording option hold the PC/USB switch (8) for four seconds. Both LEDs of the PC/USB (8) and TEL (7) buttons will light. The W880 is now ready for use with recording software. If one of the buttons is touched again this function will be switched off and the headset will return to the mode of the button pressed.

4. Troubleshooting

- Q. I have connected my headset base to my telephone terminal but the headset is not working.
- A. Make sure that you have the removable battery correctly fitted in the headset and that the battery has been properly charged.
- Q. The headset is working but I cannot hear telephone calls correctly.
- A. Ensure that you have the correct wiring setting by adjusting the switch (16) on the side of the headset base.
- Q. When the headset's ON/OFF button (2) is pressed, the handset lifter lifts the handset but I cannot hear the call on the headset.
- A. Ensure that the headset base is connected to the telephone's handset port and not the headset port (if the telephone has one).

Health and safety instructions

Please read the following safety and operational instructions before using your IPN Headsets product. Please keep these instructions for your reference. When using this product, these basic safety precautions and warnings should be followed to reduce the risk of fire, electric shock, injury to persons and damage to property.

General

Operating, charging and storage temperature is 0°C to 40°C (32°F to 104°F).

Warnings

- CHILDREN. Never allow children to play with the product – small parts may be a choking hazard.
- Plug the AC adaptor into the outlet nearest the equipment that is easily accessible.
- To reduce the risk of electric shock, explosion or fire, use only the supplied charger or Class 2 AC adaptor to charge the headset. Ensure that the voltage rating (e.g. 120V, 60 Hz) corresponds to the power supply you intend to use.
- Do not disassemble the product or AC adaptor as this may expose you to dangerous voltages or other risks. Incorrect reassembly can cause electric shock or fire when the product is subsequently used.
- Do not insert anything into the product because this may cause damage to the internal components or cause injury to you.
- Avoid contact with liquids. Do not locate this product near water, for example, near a bathtub, or sink, in a wet basement, or near a swimming pool.
- Discontinue use of product and contact IPN Headsets if the product overheats, has a damaged cord or plug, if the product has been dropped or damaged, or if the product has come into contact with liquids.
- This product should never be placed over or near a heat register and should not be placed in locations which do not have proper ventilation.
- If you experience a skin irritation after using this product, discontinue use and contact IPN Headsets.

- Exposure to high volume sound levels or excessive sound pressure may cause temporary or permanent damage to your hearing. Although there is no single volume setting that is appropriate for everyone, you should always use your headset with the volume set at moderate levels and avoid prolonged exposure to high volume sound levels. The louder the volume, the less time is required before your hearing could be affected. You may experience different sound levels when using your headset with different devices. The device you use and its settings affect the level of sound you hear. If you experience hearing discomfort, you should stop listening to the device through your headset and have your hearing checked by your doctor. To protect your hearing, some hearing experts suggest you:

1. Set the volume control in a low position before putting your headset on your ear and use as low volume as possible.
2. Avoid turning up the volume to block out noisy surroundings. Whenever possible, use your headset in a quiet environment with low background noise.
3. Limit the amount of time you use headsets at high volume levels.
4. Turn the volume down if the sound from the headset prevents you from hearing people speaking near you.

To avoid the risk of electric shock, explosion, fire or leakage of corrosive or toxic chemicals, please observe the following charging and battery warnings:

Charging warnings

- Use only the charger supplied by IPN Headsets to charge the product. Do not use the charger for any other purpose. Ensure that the voltage rating corresponds to the power supply you intend to use.
- Charge the headset according to the instructions supplied with the unit.
- Plug the AC adaptor or charger into an outlet that is near the equipment and will be easily accessible.
- Never charge the battery where the temperature may fall below 0°C (32°F) or rise above 40°C (104°F).
- Avoid charging the battery while it is unattended.

Headset battery warnings

The headset is equipped with a replaceable battery. To reduce the risk of fire or injury to persons read and follow these instructions.

Do not attempt to open battery in a fire.

The battery may explode. Check the local laws for disposal instructions.

Do not open or mutilate the battery. There may be corrosive materials which can cause damage to eyes or skin and may be toxic if swallowed.

Charge the headset according to the instructions supplied with the headset.

RECYCLING: the battery used in your headset must be recycled or disposed of properly. Contact your local recycling centre for proper disposal of your headset.

Europe Declaration

This product is CE marked according to the provisions of the R and TTE Directive (99/5/EC). This product is in compliance with the essential requirements and other relevant provisions of Directive 1999/5/EC.

Safety:	EN 60 950-01:2006+A11:2009
EMC:	EN 301 489-6 V1.3.1:2008-08
	EN 301 489-1 V1.8.1:2008-04
	EN 55022:2006+A1
	EN 55024:1998+A1+A2
	EN 61000-3-2:2006
	EN 61000-3-3:5005+A1+A2
RF:	EN 301 406 V2.1.1:2009-07
RF Safety:	EN 50360:2001 (Headset)
	EN 50385:2002 (Base)

Only to be used together with the delivered certified AC main adaptor with a GS mark.

Within the EU this product is intended to be used in Austria, Belgium, Denmark, Finland, France, Germany, Greece, Ireland, Italy, Luxembourg, The Netherlands, Portugal, Spain, Sweden, United Kingdom, Cyprus, Czech Republic, Estonia, Hungary, Latvia, Lithuania, Malta, Poland, Slovakia and Slovenia and within EFTA in Iceland, Norway and Switzerland.



CB

